

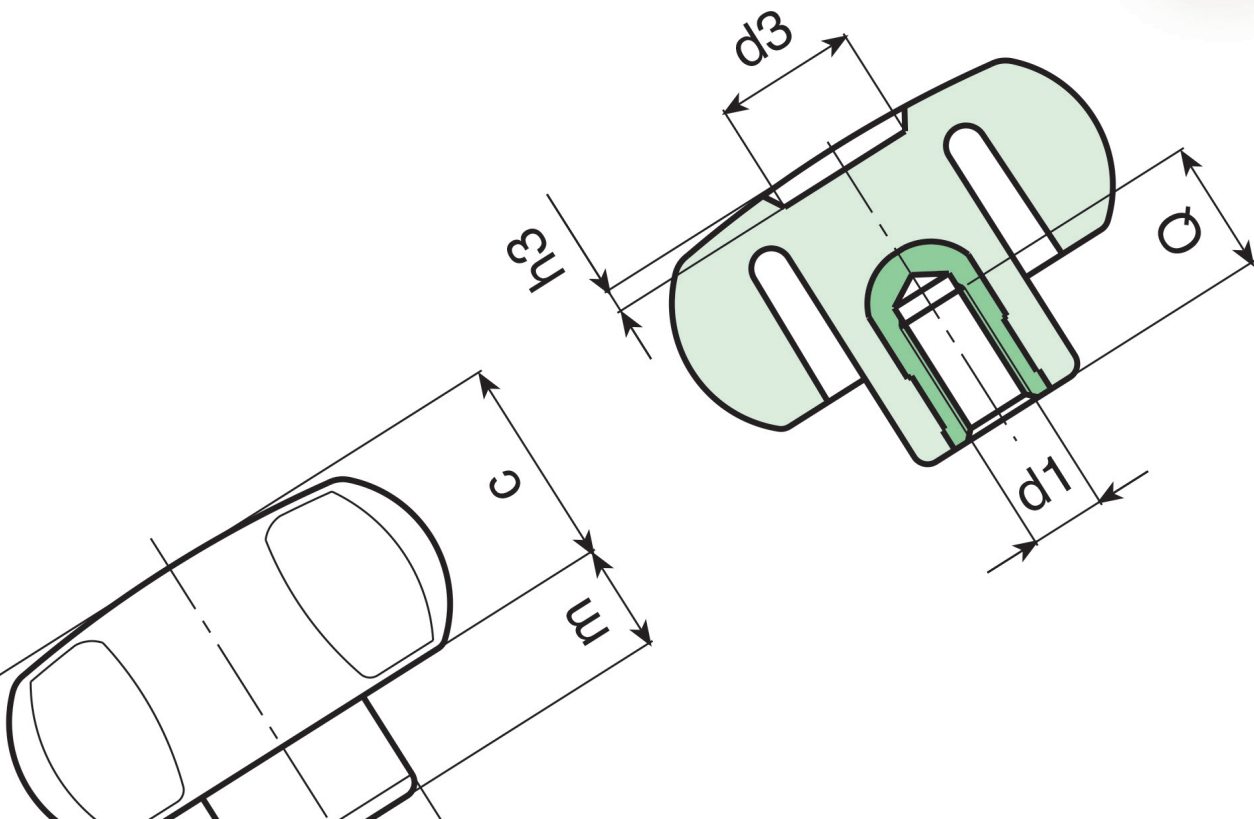

BOTTECO[®]

Family G

LOCKING HANDWHEELS



G630



4 LOBES HANDWHEEL WITH INDEXED INSERT (PUSH TO USE) AND FEMALE THREAD

Material:
(3-4) Special high resistance glass fiber reinforced technopolymer. Oils and greases resistant.

Surface:
(1-3-4) Satin.

Colour:
(3-4) Black (RAL 9011).

Central fixing button:
(1) Red polyamide (RAL 3000 cod. 16).

Alternative Cap Colour:
Orange (RAL 2004 cod. 02)
Blue (RAL 5015 cod. 07)
Yellow (RAL 1021 cod. 10)
Red (RAL 3000 cod. 16)
Green (RAL 6024 cod. 17)
Black (RAL 9011 cod. 01)

Main Insert:
Brass blind threaded bush (tolerance 6H).

Spring:
(2) Stainless steel spring (Aisi 302)



SPECIAL REQUEST:

- It is possible to supply the inserts in different materials, on request and for quantities.
- It is possible to supply colours as shown in the table at pag. G-27, on request and for quantities.

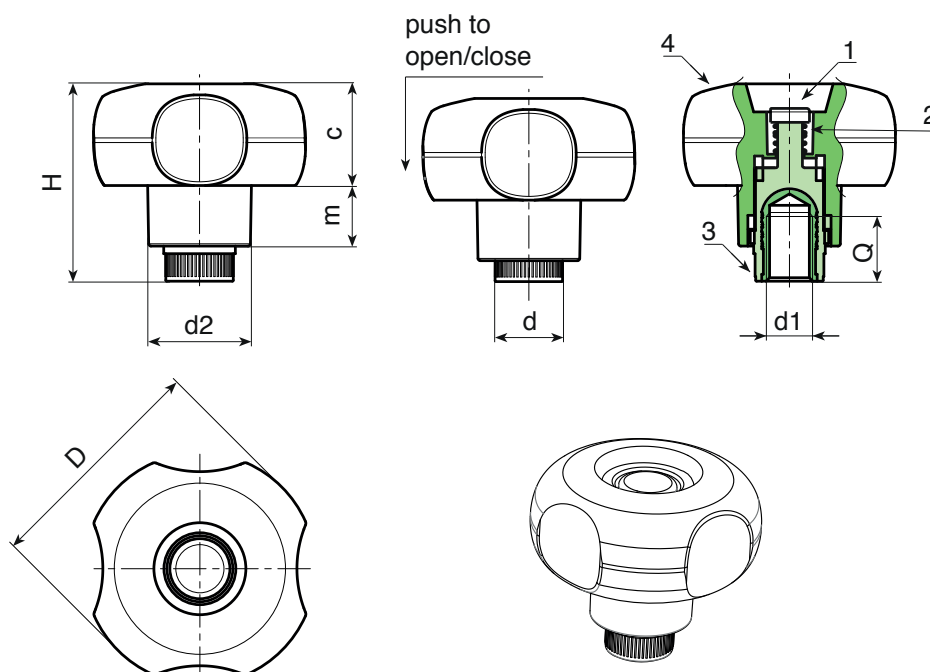

art.	D	H	d2	d	m	c	d1 6H	Q	g
G63050.TM060116	49	42,5	22	15	13	22	M06	14	37
G63050.TM080116	49	42,5	22	15	13	22	M08	14	37
G63050.TM100116	49	42,5	22	15	13	22	M10	14	38

G632



4 LOBES HANDWHEEL WITH INDEXED INSERT (PUSH TO USE) AND MALE THREAD

Material:
(3-4) Special high resistance glass fiber reinforced technopolymer. Oils and greases resistant.

Surface:
(1-3-4) Satin.

Colour:
(3-4) Black (RAL 9011).

Central fixing button:
(1) Red polyamide (RAL 3000 cod. 16).

Alternative Cap Colour:
Orange (RAL 2004 cod. 02)
Blue (RAL 5015 cod. 07)
Yellow (RAL 1021 cod. 10)
Red (RAL 3000 cod. 16)
Green (RAL 6024 cod. 17)
Black (RAL 9011 cod. 01)

Main Insert:
Zinc plated steel threaded stud (tolerance 6g).

Spring:
(2) Stainless steel spring (Aisi 302)



SPECIAL REQUEST:

- It is possible to supply inserts in different lengths or by special design, on request and for quantities.
- It is possible to supply the inserts in different materials, on request and for quantities.
- It is possible to supply colours as shown in the table at pag. G-27, on request and for quantities.

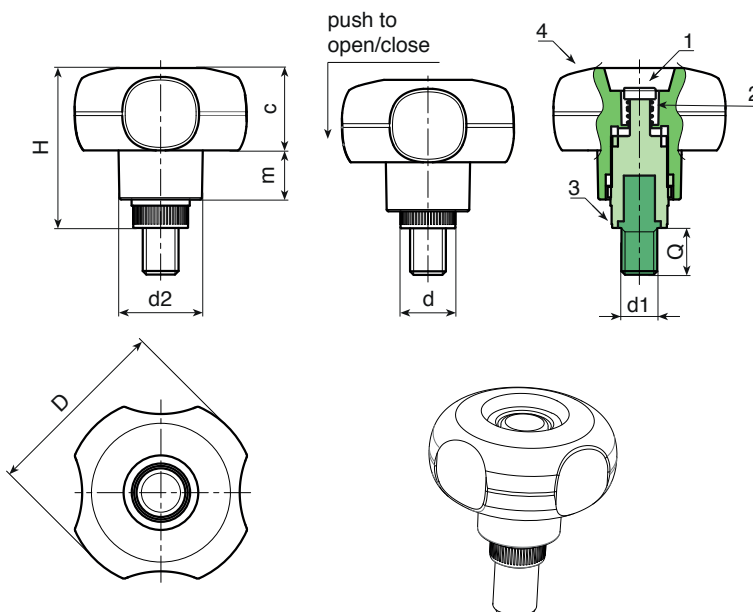

art.	D	H	d2	d	m	c	LM	d1 6g	Q	g
G63250.TM06X..0116	49	42,5	22	15	13	22	90	M06	A.R.	-
G63250.TM08X..0116	49	42,5	22	15	13	22	90	M08	A.R.	-
G63250.TM10X..0116	49	42,5	22	15	13	22	90	M10	A.R.	-

Enter the stud length choice in the two .. of the article code. Lengths by request with 250 pieces minimum quantity.

LM = Maximum mouldable length.

Presumable presence in the stock in %
90% ● 40% ● 5% ●

G130



“EUROMODEL” KNURLED KNOB WITH CAP

Material:

Reinforced polyamide. Oils and greases resistant.

Surface:

Satin.

Colour:

Black (RAL 9011).

Central Cap:

Grey polyamide (RAL 7035 cod. 13) with black polyamide support ring. Push fit assembling. Removable.

Alternative Cap Colour:

Orange (RAL 2004 cod. 02)
 Blue (RAL 5015 cod. 07)
 Yellow (RAL 1021 cod. 10)
 Red (RAL 3000 cod. 16)
 Green (RAL 6024 cod. 17)
 Black (RAL 9011 cod. 01)



Inserts:

Version TD:

Zinc plated steel insert with threaded through-hole (H10 tolerance).

Version TM:

Zinc plated steel insert with smooth through-hole (6H tolerance).

Fixing bore d2:

Version TD: Lateral thread hole for fixing.

Version TM: None.

SPECIAL REQUEST:

- It's possible to supply the inserts with d1 bore by customer design, on request and for quantities.
- It is possible to supply the inserts in different materials, on request and for quantities.
- It is possible to supply colours as shown in the table at pag. G-27, on request and for quantities.

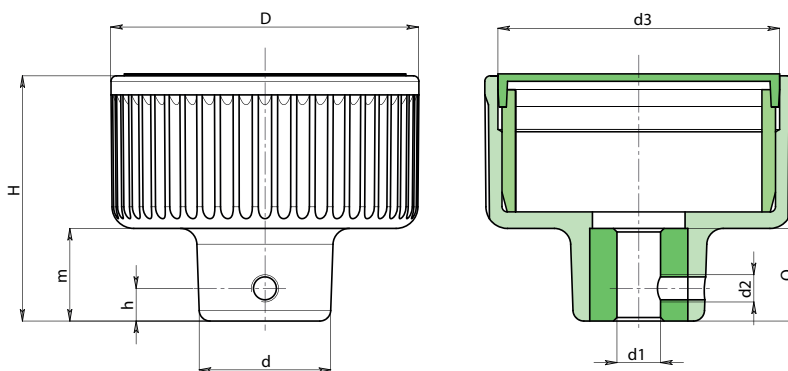

Version: TD with smooth right-trough hole.

art.	D	d	H	m	h	d2	d3	d1 H10	dm	Q	g
G130057.TD080113	57	24	46	17	6	M5	52	08	12	16	105
G130072.TD080113	72	28	53	21	6	M5	67	08	12	20	165
G130094.TD100113	94	36	58	24	6	M5	87	10	15	24	376

Attention: bore d1 (H10 tolerance) could be produced by request, with 50 pieces minimum.

Dm = It's possible to increase the hole, by boring, until Dm (enlarge).

Version TM: with threaded right-trough hole.

art.	D	d	H	m	h	d2	d3	d1 6H	dm	Q	g
G130057.TM080113	57	24	46	17	-	-	52	M08	12	16	105
G130072.TM100113	72	28	53	21	-	-	67	M10	12	20	165
G130094.TM120113	94	36	58	24	-	-	87	M12	15	24	376

Attention: bore d1 (H10 tolerance) could be produced by request, with 50 pieces minimum.

Dm = It's possible to increase the hole, by boring, until Dm (enlarge).

G210



PUSH FIT INDICATOR KNOB WITH HALFMOON HOLE

Material:
Reinforced polypropylene.

Surface:
Satin.

Colour:
Black (RAL 9011).

Pointer Colour:
White line obtained by pad printing.

Hole:
Halfmoon-shaped smooth female hole obtained by moulding.

Fixing:
Push fit.

SPECIAL REQUEST:
• None.

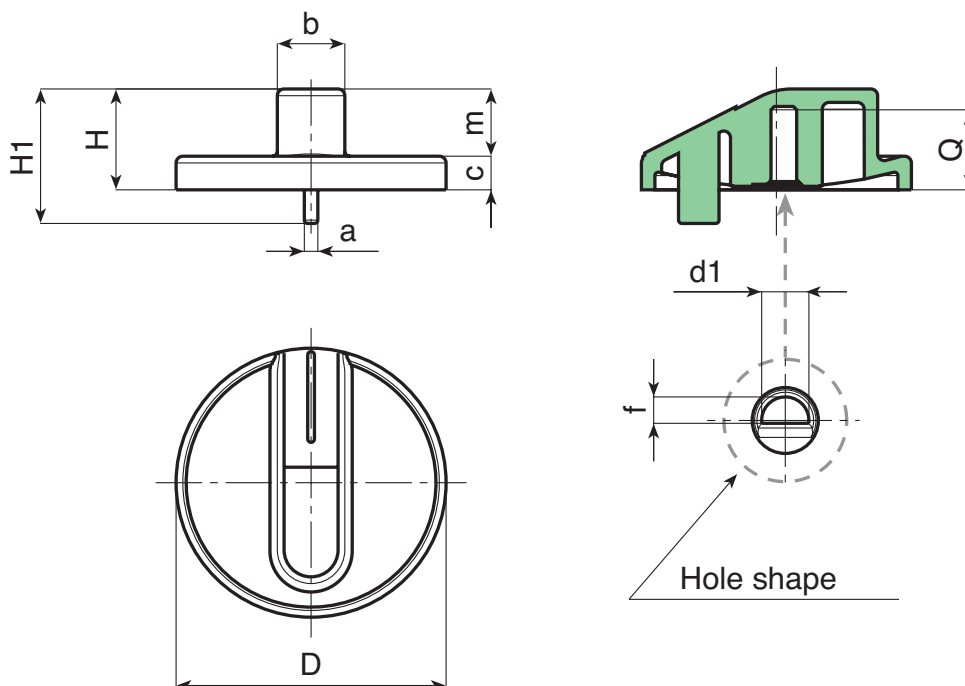

	art.	D	H	H1	a	b	c	m	f	d1	Q	g
●	G21040.TG0601Z1	39,5	15	20	2	9,5	5	10	3,8	06	12	5

Presumable presence in the stock in %
● 90% ● 40% ● 5%

G650



6-LOBE HANDWHEEL WITH CAP AND THREADED FEMALE INSERT

Material:

Reinforced polyamide.
Oils and greases resistant.

Surface:

Satin.

Colour:

Black (RAL 9011).

Central Cap:

Grey polyamide (RAL 7035 cod. 13).

Alternative Cap Colour:

Orange (RAL 2004 cod. 02)
Blue (RAL 5015 cod. 07)
Yellow (RAL 1021 cod. 10)
Red (RAL 3000 cod. 16)
Green (RAL 6024 cod. 17)
Black (RAL 9011 cod. 01)

Main Insert:

Brass blind threaded bush (tolerance 6H).



SPECIAL REQUEST:

- It is possible to supply the inserts in different materials, on request and for quantities.
- It is possible to supply colours as shown in the table at pag. G-27, on request and for quantities.

PAD PRINTING SERVICE:

- Upon request and for special quantities caps can be supplied with customized pad printing.

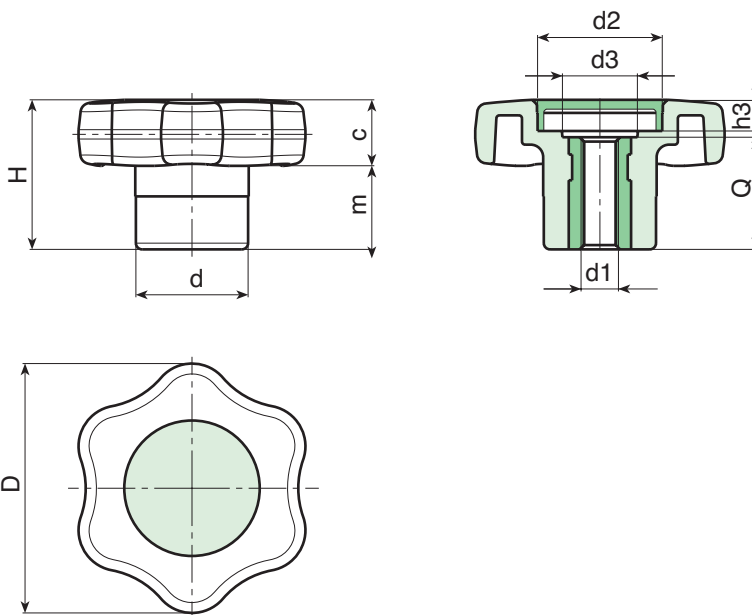

	art.	D	H	d	m	c	d2	d3	h3	d1 6H	Q	△ g
●	G65040.TM0601	40	24	18	10,5	13,5	20	13	6	M06	18	18
●	G65040.TM0801	40	24	18	10,5	13,5	20	13	6	M08	18	19
●	G65040.TM1001	40	24	18	10,5	13,5	20	13	6	M10	18	20

G651



6-LOBE HANDWHEEL WITH CAP AND THREADED STUD

Material:

Reinforced polyamide.
Oils and greases resistant.

Surface:

Satin.

Colour:

Black (RAL 9011).

Central Cap:

Grey polyamide (RAL 7035 cod. 13).

Alternative Cap Colour:

Orange (RAL 2004 cod. 02)
Blue (RAL 5015 cod. 07)
Yellow (RAL 1021 cod. 10)
Red (RAL 3000 cod. 16)
Green (RAL 6024 cod. 17)
Black (RAL 9011 cod. 01)

Main Insert:

Zinc plated steel threaded stud (tolerance 6g).



SPECIAL REQUESTS:

- It is possible to supply inserts in different lengths or by special design, on request and for quantities.
- It is possible to supply inserts in different materials, on request and for quantities.
- It is possible to supply colours as shown in the table on page G-27, on request and for quantities.

PAD PRINTING SERVICE:

- Upon request and for special quantities caps can be supplied with customized pad printing.

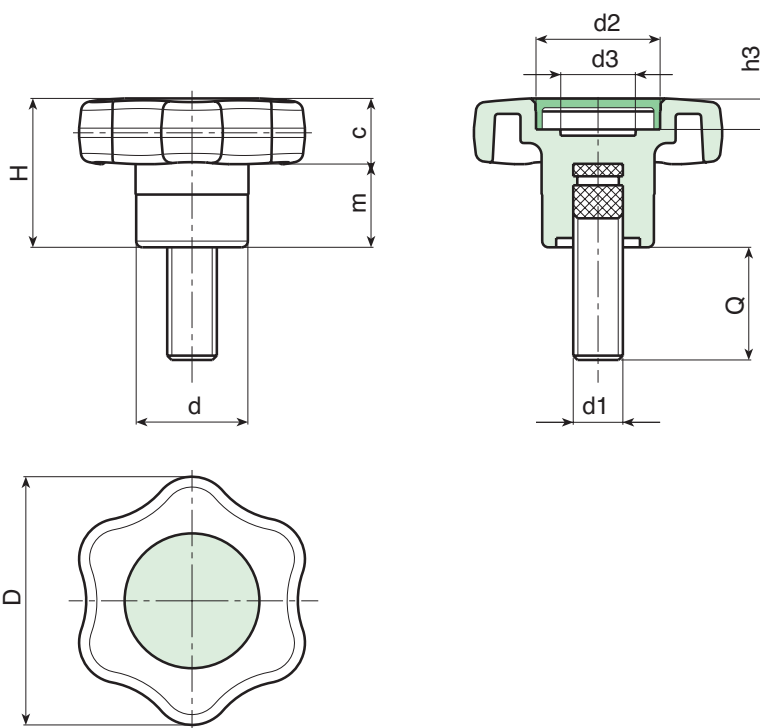

	art.	D	H	d	m	c	d2	d3	h3	d1 6g	Q	⚖ g
●	G65140.TM06X..01	40	24	18	13,5	10,5	20	13	6	M06	A.R.	-
●	G65140.TM08X3001	40	24	18	13,5	10,5	20	13	6	M08	30	24
●	G65140.TM10X..01	40	24	18	13,5	10,5	20	13	6	M10	A.R.	-

LM = Maximum mouldable length.

It's possible to have different lengths, by customers requests. Minimum 100 pieces.

Presumable presence in the stock in %
 90% ● 40% ● 5% ●

G730



PA6
+G.F.

UL94
HB

RoHS
COMPLIANT

4-LOBE HANDWHEEL WITH THREADED FEMALE INSERT

Material:

Reinforced polyamide. Oils and greases resistant.

Surface: Satin.

Colour: Black (RAL 9011).

Main Insert:

Brass blind threaded bush (tolerance 6H).

(*) Zinc plated steel blind threaded bush (tolerance 6H).



SPECIAL REQUEST:

- It is possible to supply the inserts in different materials, on request and for quantities.
- It is possible to supply colours as shown in the table at pag. G-27, on request and for quantities.

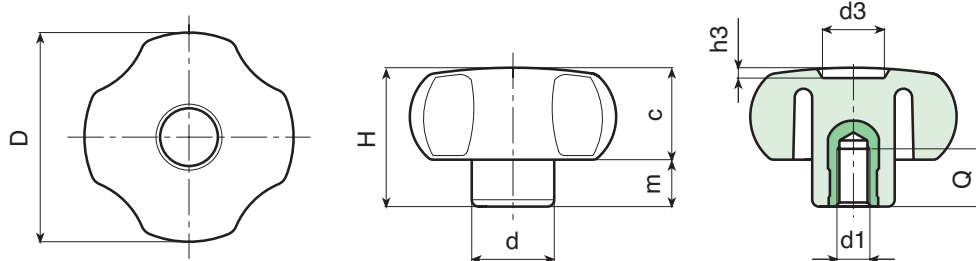

	art.	D	H	d	c	m	d3	h3	d1 6H	Q	△ g
●	G73020.TM0401	21	14	11	8,5	5,5	8	1,5	M04	13	5
●	G73020.TM0501	21	14	11	8,5	5,5	8	1,5	M05	13	5
●	G73020.TM0601	21	14	11	8,5	5,5	8	1,5	M06	13	5
●	G73025.TM0401	26	16	12	10	6	10	1,5	M08	7	6
●	G73025.TM0501	26	16	12	10	6	10	1,5	M05	7	6
●	G73025.TM0601	26	16	12	10	6	10	1,5	M06	7	7
●	G73025.TM0801	26	16	12	10	6	10	1,5	M08	7	8
●	G73030.TM0501	30	23	15	13,5	9,5	12	2	M05	13	12
●	G73030.TM0601	30	23	15	13,5	9,5	12	2	M06	10	12
●	G73030.TM0801	30	23	15	13,5	9,5	12	2	M08	16	14
●	G73030.TM1001	30	23	15	13,5	9,5	12	2	M10	16	14
●	G73040.TM0501	40,5	29,5	15,5	18,5	11	12	3	M05	13	21
●	G73040.TM0601	40,5	29,5	15,5	18,5	11	12	3	M06	10	21
●	G73040.TM0801	40,5	29,5	15	18,5	11	12	3	M08	14	22
●	G73040.TM1001	40,5	29,5	17,5	18,5	11	12	3	M10	13	26
●	G73040.TM1201	40,5	29,5	21	18,5	11	12	3	M12	11	30
●	G73050.TM0601	49	32	20,5	21,5	11	14,5	2,5	M06	10	35
●	G73050.TM0801	49	32	20,5	21,5	11	14,5	2,5	M08	14	42
●	G73050.TM1001	49	32	20,5	21,5	11	14,5	2,5	M10	13	43
●	G73050.TM1201	49	32	20,5	21,5	11	14,5	2,5	M12	17	48
●	G73060.TM0801	59	40	23	25	15	24	4	M08	15	60
●	G73060.TM1001	59	40	23	25	15	24	4	M10	14	62
●	G73060.TM1201	59	40	23	25	15	24	4	M12	18	67
●	G73060.TM1401	59	40	23	25	15	24	4	M14	19	70
●	G73060.TM1601	59	40	23	25	15	24	4	(*) M16	17	82
●	G73080.TM1001	79	41	30	24	17	21	3	M10	14	88
●	G73080.TM1201	79	41	30	24	17	21	3	M12	16	88
●	G73080.TM1401	79	41	30	24	17	21	3	M14	19	97
●	G73080.TM1601	79	41	30	24	17	21	3	(*) M16	17	109
●	G73080.TM2001	79	41	30	24	17	21	3	(*) M20	16	115

G731



4-LOBE HANDWHEEL WITH THREADED FEMALE THROUGH INSERT

Material:
Reinforced polyamide.
Oils and greases resistant.

Surface:
Satin.

Colour:
Black (RAL 9011).

Main Insert:
Brass right through threaded bush (tolerance 6H).
(*) Zinc plated steel right through threaded bush (tolerance 6H).

SPECIAL REQUEST:

- It is possible to supply the inserts in different materials, on request and for quantities.
- It is possible to supply colours as shown in the table at pag. G-27, on request and for quantities.

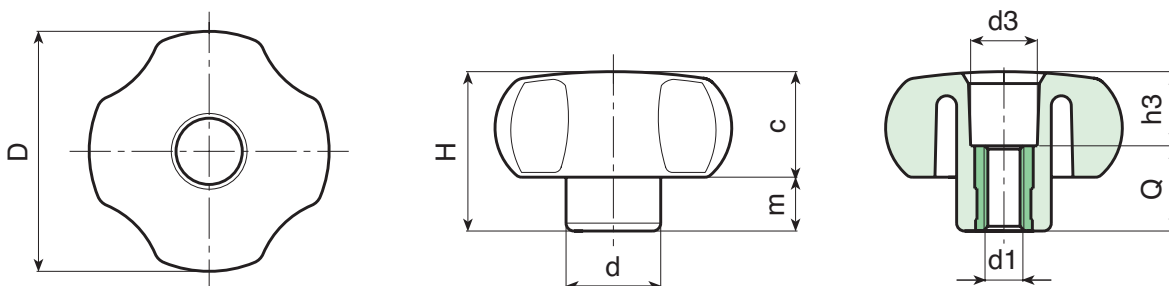

	art.	D	H	d	c	m	d3	h3	d1 6H	Q	Δ g
●	G73120.TM0401	21	14	11	8,5	5,5	8	4,5	M04	9,5	4
●	G73120.TM0501	21	14	11	8,5	5,5	8	7,5	M05	6,5	5
●	G73120.TM0601	21	14	11	8,5	5,5	8	7,5	M06	6,5	5
●	G73125.TM0401	26	16	12	10	6	9	7,5	M08	8,5	5
●	G73125.TM0501	26	16	12	10	6	9	9,5	M05	6,5	6
●	G73125.TM0601	26	16	12	10	6	9	9,5	M06	6,5	6
●	G73125.TM0801	26	16	12	10	6	10,5	1,5	M08	14,5	10
●	G73130.TM0501	30	23	15	13,5	9,5	12	8,5	M05	14,5	11
●	G73130.TM0601	30	23	15	13,5	9,5	12	8,5	M06	14,5	11
●	G73130.TM0801	30	23	15	13,5	9,5	12	8,5	M08	14,5	12
●	G73130.TM1001	30	23	15	13,5	9,5	12	8,5	M10	14,5	13
●	G73140.TM0601	40,5	29,5	15,5	18,5	11	13	11,5	M06	18	21
●	G73140.TM0801	40,5	29,5	15	18,5	11	13	11,5	M08	18	21
●	G73140.TM1001	40,5	29,5	17,5	18,5	11	13	11,5	M10	18	23
●	G73140.TM1201	40,5	29,5	21	18,5	11	13	11,5	M12	18	26
●	G73150.TM0601	49	32	20,5	21,5	11	13,5	14,5	M06	18	37
●	G73150.TM0801	49	32	20,5	21,5	11	13,5	14,5	M08	18	38
●	G73150.TM1001	49	32	20,5	21,5	11	13,5	14,5	M10	18	39
●	G73150.TM1201	49	32	20,5	21,5	11	13,5	14,5	M12	18	40
●	G73160.TM0801	59	40	23	25	15	20	22	M08	18	54
●	G73160.TM1001	59	40	23	25	15	20	22	M10	18	55
●	G73160.TM1201	59	40	23	25	15	20	22	M12	18	55
●	G73160.TM1401	59	40	23	25	15	20	22	M14	18	56
●	G73180.TM1001	79	41	30	24	17	20	23	M10	18	82
●	G73180.TM1201	79	41	30	24	17	20	23	M12	18	79
●	G73180.TM1401	79	41	30	24	17	20	23	M14	18	80
●	G73180.TM1601	79	41	30	24	17	21	15	(*) M16	26	102

Presumable presence in the stock in %

90% ● 40% ● 5% ●

G732



4-LOBE HANDWHEEL WITH THREADED STUD

Material:
Reinforced polyamide. Oils and greases resistant.

Surface: Satin.

Colour: Black (RAL 9011).

Main Insert: Zinc plated steel threaded stud (tolerance 6g).

SPECIAL REQUESTS:

- It is possible to supply inserts in different lengths or by special design, on request and for quantities.
- It is possible to supply inserts in different materials, on request and for quantities.
- It is possible to supply colours as shown in the table on page G-27, on request and for quantities.

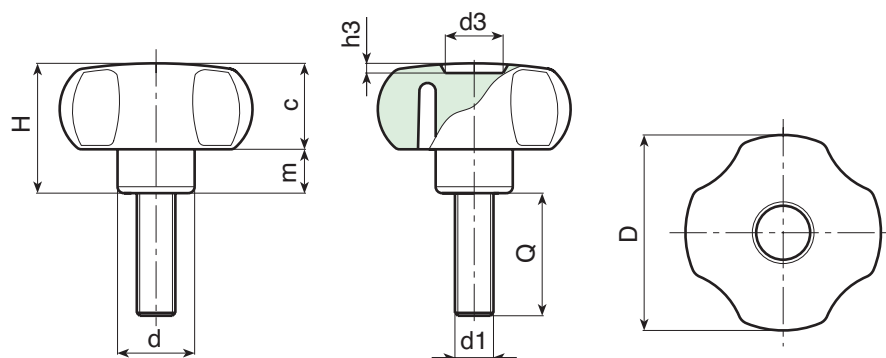

art.	D	H	d	c	m	d3	h3	LM	d1 6g	Q	g
G73220.TM04X..01	21	14	11	8,5	5,5	8	1,5	50	M04	10-16-20	4-4,5-5
G73220.TM05X..01	21	14	11	8,5	5,5	8	1,5	50	M05	10-16-20-30-50	6-6,5-7-8-10
G73220.TM06X..01	21	14	11	8,5	5,5	8	1,5	50	M06	10-16-20-30-40	6,5-7,5-8-9,5-11
G73225.TM04X..01	26	16	12	10	6	10	1,5	95	M04	A.R.	-
G73225.TM05X..01	26	16	12	10	6	10	1,5	95	M05	10-16-20-25	8-8,5-9-9,5
G73225.TM06X..01	26	16	12	10	6	10	1,5	95	M06	10-16-20-25-30	10-11-13-14-15
G73225.TM08X..01	26	16	12	10	6	10	1,5	90	M08	16-20-30-40	14-16-20-24
G73230.TM05X..01	30	23	15	13,5	9,5	12	2	90	M05	20-30	13-14
G73230.TM06X..01	30	23	15	13,5	9,5	12	2	90	M06	10-16-20-30-40-50	14-15-16-18-20-22
G73230.TM08X..01	30	23	15	13,5	9,5	12	2	90	M08	16-20-30-40-50	20-22-25-28-31
G73230.TM10X..01	30	23	15	13,5	9,5	12	2	90	M10	20-50	25-43
G73240.TM06X..01	40,5	29,5	15,5	18,5	11	12	3	100	M06	10-16-20-30-40	23-24-26-28-30
G73240.TM08X..01	40,5	29,5	15	18,5	11	12	3	100	M08	16-20-30-40-50	28-31-34-37-40
G73240.TM10X..01	40,5	29,5	17,5	18,5	11	12	3	100	M10	20-30	38-43
G73240.TM12X..01	40,5	29,5	21	18,5	11	12	3	100	M12	A.R.	-
G73250.TM06X2001	49	32	20,5	21,5	11	14,5	2,5	120	M06	20	43
G73250.TM08X..01	49	32	20,5	21,5	11	14,5	2,5	120	M08	16-20-30-40-50-60	49-51-54-57-60-64
G73250.TM10X..01	49	32	20,5	21,5	11	14,5	2,5	120	M10	15-20-30-40-50-60	55-58-63-68-72-77
G73250.TM12X..01	49	32	20,5	21,5	11	14,5	2,5	120	M12	30-50	77-90
G73260.TM08X..01	59	40	23	25	15	24	4	120	M08	16-20-30-40-50	73-76-79-81
G73260.TM10X..01	59	40	23	25	15	24	4	120	M10	20-30-60	79-84-100
G73260.TM12X..01	59	40	23	25	15	24	4	120	M12	25-30-40-50-60	94-97-104-111-119
G73260.TM14X..01	59	40	23	25	15	24	4	120	M14	A.R.	-
G73280.TM10X..01	79	41	30	24	17	21	3	80	M10	A.R.	-
G73280.TM12X..01	79	41	30	24	17	21	3	80	M12	25-45-50-60	115-132-135-142
G73280.TM14X..01	79	41	30	24	17	21	3	80	M14	A.R.	-
G73280.TM16X..01	79	41	30	24	17	21	3	80	M16	A.R.	-

LM = Maximum mouldable length. It's possible to have different lengths, by customers requests. Minimum 100 pieces.

G733



4-LOBE HANDWHEEL WITH SMOOTH HOLE INSERT

Material:
Reinforced polyamide.
Oils and greases resistant.

Surface:
Satin.

Colour:
Black (RAL 9011).

Main Insert:
(*) Brass insert with smooth blind hole (H7 tolerance).
ATTENTION: bore cannot be enlarged.

(#) Zinc plated steel insert with smooth blind hole (H10 tolerance).



SPECIAL REQUEST:

- It is possible to supply the inserts in different materials, on request and for quantities.
- It is possible to supply colours as shown in the table at pag. G-27, on request and for quantities.

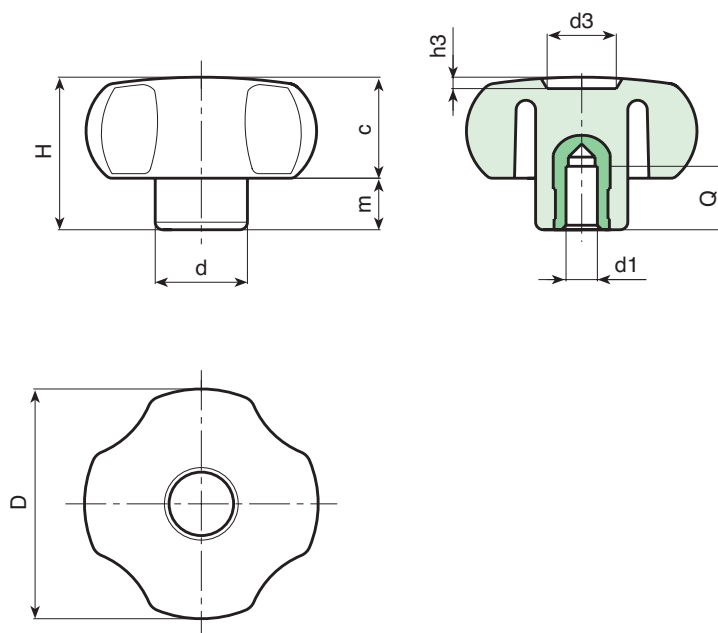

	art.	D	H	d	c	m	d3	h3	Dm	d1 H7	Q	g
●	G73330.TD0601	30	23	15	13,5	9,5	12	2	-	(*) 06	15	16
●	G73330.TD0801	30	23	15	13,5	9,5	12	2	-	(*) 08	15	17
●	G73340.TD0601	40,5	29,5	15,5	18,5	11	12	3	-	(*) 06	15	24
●	G73340.TD0801	40,5	29,5	15	18,5	11	12	3	-	(*) 08	15	28
●	G73340.TD1001	40,5	29,5	17,5	18,5	11	12	3	-	(*) 10	15	30
●	G73350.TD0601	49	32	20,5	21,5	11	14,5	2,5	12	(#) 06	18	60
●	G73350.TD0801	49	32	20,5	21,5	11	14,5	2,5	12	(#) 08	18	62
●	G73350.TD1001	49	32	20,5	21,5	11	14,5	2,5	12	(#) 10	18	63
●	G73360.TP0501	59	40	23	25	15	24	4	12	(#) 05	18	90
●	G73360.TD0801	59	40	23	25	15	24	4	12	(#) 08	18	93
●	G73360.TD1001	59	40	23	25	15	24	4	12	(#) 10	18	96
●	G73380.TP0501	79	41	30	24	17	21	3	18	(#) 05	24	165
●	G73380.TD0801	79	41	30	24	17	21	3	18	(#) 08	24	159
●	G73380.TD1201	79	41	30	24	17	21	3	18	(#) 12	24	153

Attention: (#) bore d1 (H10 tolerance) could be produced by request, with 200 pieces minimum.

Dm = It's possible to increase the hole, by boring, until Dm (enlarge).

Presumable presence in the stock in %

90% ●

40% ●

5% ●

G734



4-LOBE HANDWHEEL WITH ELONGATED HUB AND THREADED FEMALE INSERT

Material:
Reinforced polyamide.
Oils and greases resistant.

Surface:
Satin.

Colour:
Black (RAL 9011).

Main Insert:
Brass blind threaded bush (tolerance 6H).



G

SPECIAL REQUEST:

- It is possible to supply the inserts in different materials, on request and for quantities.
- It's possible to supply the handwheels with hubs by drawing, on request and for quantities.

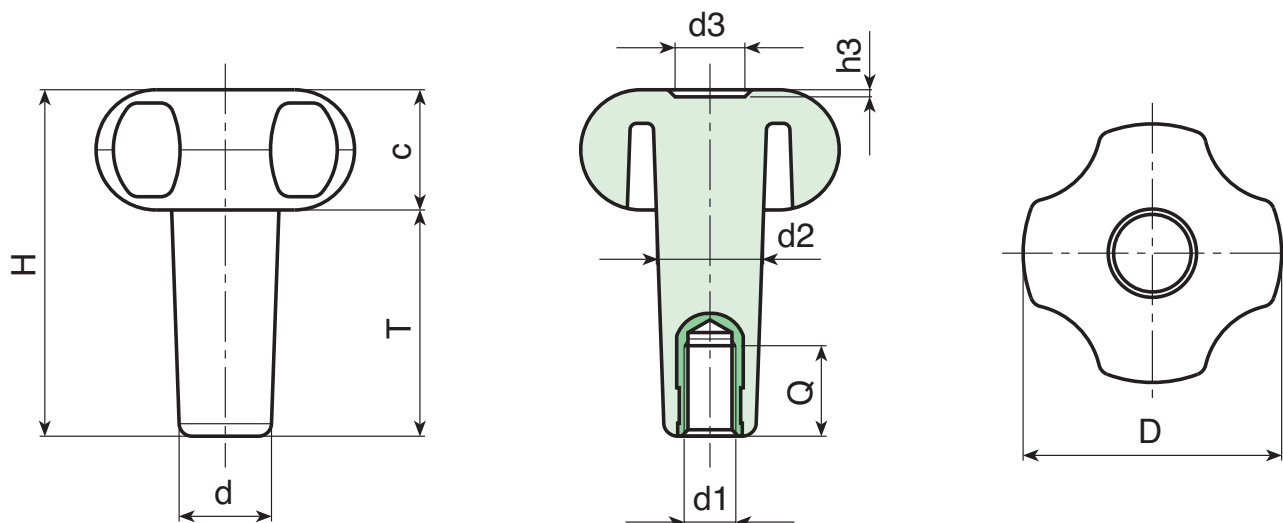

	art.	D	H	T	d	c	d2	d3	h3	d1	Q	g
●	G73430.T25M0601	30	37,5	23,5	13,5	14	14,5	12	2	M06	10	15
●	G73430.T35M0601	30	47	33,5	13,5	14	15	12	2	M06	16	16
●	G73430.T35M0801	30	47	33,5	13,5	14	15	12	2	M08	21	17
●	G73440.T35M1001	41	54	35	16,5	19	17	12	3	M10	15	30
●	G73440.T66M0601	41	85	66	16,5	19	18	12	3	M06	18	35
●	G73450.T40M0801	52	61	39	17,5	22	19	14	2,5	M08	15	47
●	G73450.T40M1001	52	61	39	17,5	22	19	14	2,5	M10	15	49
●	G73450.T50M0801	52	71	49	18	22	20,5	14	2,5	M08	15	55
●	G73450.T50M1001	52	71	49	18	22	20,5	14	2,5	M10	15	56
●	G73450.T60M1001	52	80	58	18	22	21	14	2,5	M10	15	62
●	G73460.T60M0801	59	83	58	23	25	24	24	4	M08	21	91
●	G73460.T60M1001	59	83	58	23	25	24	24	4	M10	15	91
●	G73460.T60M1201	59	83	58	23	25	24	24	4	M12	21	96
●	G73460.T80M0801	59	103	78	23	25	24	24	4	M08	21	105
●	G73460.T80M1001	59	103	78	23	25	24	24	4	M10	15	104
●	G73460.T80M1201	59	103	78	23	25	24	24	4	M12	21	107

G735



4-LOBE HANDWHEEL WITH ELONGATED HUB AND THREADED STUD

Material:
Reinforced polyamide.
Oils and greases resistant.

Surface:
Satin.

Colour:
Black (RAL 9011).

Main Insert:
Zinc plated steel threaded stud (tolerance 6g).



SPECIAL REQUESTS:

- It is possible to supply inserts in different lengths or by special design, on request and for quantities.
- It is possible to supply inserts in different materials, on request and for quantities.
- It's possible to supply the handwheels with hubs by drawing, on request and for quantities.

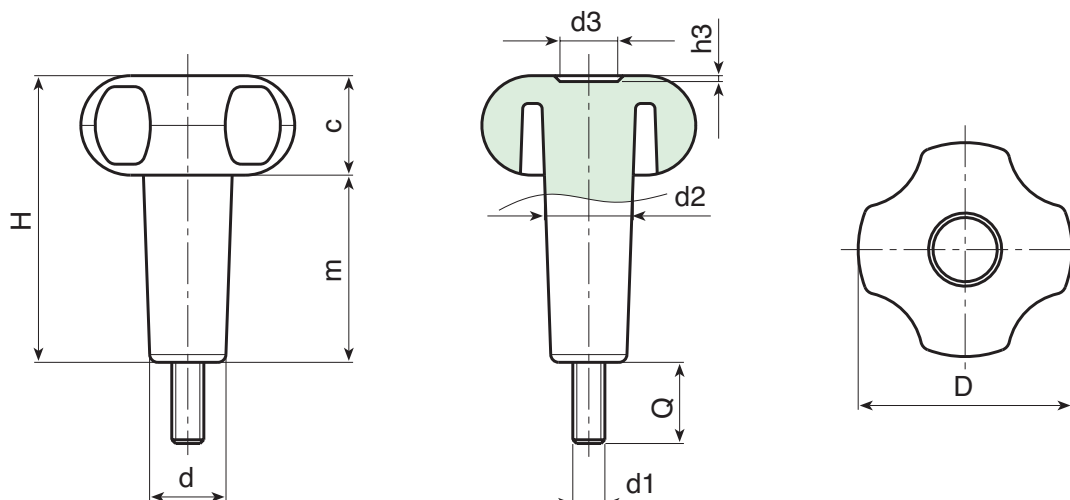

	art.	D	H	T	d	c	d2	d3	h3	LM	d1	Q	g
●	G73530.T35M06X1501	30	47	33,5	13,5	14	15	12	2	65	M06	15	23
●	G73530.T35M08X3001	30	47	33,5	13,5	14	15	12	2	65	M08	30	36
●	G73540.T35M08X2001	41	54	35	16,5	19	17	12	3	80	M08	20	49
●	G73540.T35M10X1501	41	54	35	16,5	19	17	12	3	80	M10	15	54
●	G73550.T40M08X1501	52	61	39	17,5	22	19	14	2,5	90	M08	15	60
●	G73550.T40M10X4001	52	61	39	17,5	22	19	14	2,5	90	M10	40	82
●	G73550.T50M08X..01	52	71	49	18	22	20,5	14	2,5	80	M08	A.R.	75
●	G73550.T60M08X3001	52	80	58	18	22	21	14	2,5	70	M08	30	86
●	G73560.T60M08X..01	59	83	58	23	25	24	24	4	75	M08	A.R.	115
●	G73560.T60M10X4001	59	83	58	23	25	24	24	4	75	M10	40	138
●	G73560.T80M10X..01	59	103	78	23	25	24	24	4	55	M10	A.R.	150

LM = Maximum mouldable length.

It's possible to have different lengths, by customers request. Minimum 100 pieces.

Presumable presence in the stock in %
● 90% ● 40% ● 5%

G745-G746



4-LOBE HANDWHEEL WITH CAP WITH THREADED FEMALE INSERT BLIND AND RIGHT THROUGH

Material:
Reinforced polyamide. Oils and greases resistant.

Surface: Satin.

Colour: Black (RAL 9011).

Central Cap: Grey polyamide (RAL 7035 cod. 13).

Alternative Cap Colour:

Orange (RAL 2004 cod. 02) Blue (RAL 5015 cod. 07)
Yellow (RAL 1021 cod. 10) Green (RAL 6024 cod. 17)
Red (RAL 3000 cod. 16) Black (RAL 9011 cod. 01)

Main Insert:

G745: Brass blind threaded bush (tolerance 6H).
G746: Brass right through threaded bush (tolerance 6H).



SPECIAL REQUEST:

- It is possible to supply the inserts in different materials, on request and for quantities.
- It is possible to supply colours as shown in the table at pag. G-27, on request and for quantities.

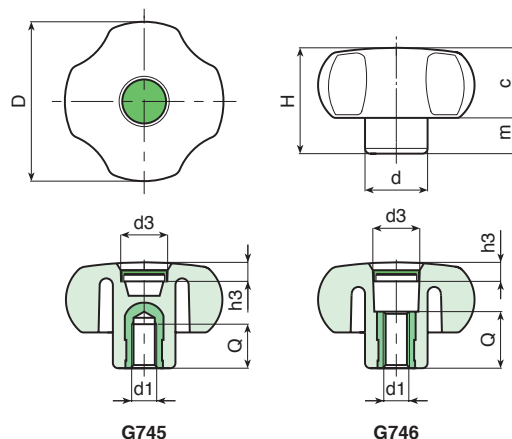

Version G745: with blind threaded insert.

art.	D	H	d	c	m	d3	h3	d1 6H	Q	g
G74540.TM0501	40,5	29,5	15,5	18,5	11	18	7,5	M05	10	18
G74540.TM0601	40,5	29,5	15,5	18,5	11	18	7,5	M06	13	18
G74540.TM0801	40,5	29,5	15	18,5	11	18	7,5	M08	13	19
G74540.TM1001	40,5	29,5	17,5	18,5	11	18	7,5	M10	13	23
G74540.TM1201	40,5	29,5	21	18,5	11	18	7,5	M12	13	27
G74550.TM0601	49	32	20,5	21,5	11	20	7,5	M06	13	32
G74550.TM0801	49	32	20,5	21,5	11	20	7,5	M08	13	39
G74550.TM1001	49	32	20,5	21,5	11	20	7,5	M10	13	40
G74550.TM1201	49	32	20,5	21,5	11	20	7,5	M12	13	44
G74560.TM0801	59	40	23	25	15	22	7,5	M08	13	55
G74560.TM1001	59	40	23	25	15	22	7,5	M10	13	57
G74560.TM1201	59	40	23	25	15	22	7,5	M12	17	62
G74560.TM1401	59	40	23	25	15	22	7,5	M14	17	65

Version G746: with right through threaded insert.

art.	D	H	d	c	m	d3	h3	d1 6H	Q	g
G74640.TM0501	40,5	29,5	15,5	18,5	11	20	7,5	M05	18	17
G74640.TM0601	40,5	29,5	15,5	18,5	11	20	7,5	M06	18	17
G74640.TM0801	40,5	29,5	15	18,5	11	20	7,5	M08	18	18
G74640.TM1001	40,5	29,5	17,5	18,5	11	20	7,5	M10	18	22
G74640.TM1201	40,5	29,5	21	18,5	11	20	7,5	M12	18	26
G74650.TM0601	49	32	20,5	21,5	11	20	7,5	M06	18	31
G74650.TM0801	49	32	20,5	21,5	11	20	7,5	M08	18	38
G74650.TM1001	49	32	20,5	21,5	11	20	7,5	M10	18	39
G74650.TM1201	49	32	20,5	21,5	11	20	7,5	M12	18	43
G74660.TM0801	59	40	23	25	15	22	7,5	M08	18	54
G74660.TM1001	59	40	23	25	15	22	7,5	M10	18	56
G74660.TM1201	59	40	23	25	15	22	7,5	M12	18	61
G74660.TM1401	59	40	23	25	15	22	7,5	M14	18	64

G747



PA6
+G.F.

UL94
HB

RoHS
COMPLIANT

4-LOBE HANDWHEEL WITH CAP AND THREADED STUD

Material:
Reinforced polyamide. Oils and greases resistant.

Surface:
Satin.

Colour:
Black (RAL 9011).

Central Cap:
Grey polyamide (RAL 7035 cod. 13).

Alternative Cap Colour:
Orange (RAL 2004 cod. 02)
Blue (RAL 5015 cod. 07)
Yellow (RAL 1021 cod. 10)
Red (RAL 3000 cod. 16)
Green (RAL 6024 cod. 17)
Black (RAL 9011 cod. 01)

Main Insert:
Zinc plated steel threaded stud (tolerance 6g).



SPECIAL REQUESTS:

- It is possible to supply inserts in different lengths or by special design, on request and for quantities.
- It is possible to supply inserts in different materials, on request and for quantities.
- It is possible to supply colours as shown in the table on page G-27, on request and for quantities.

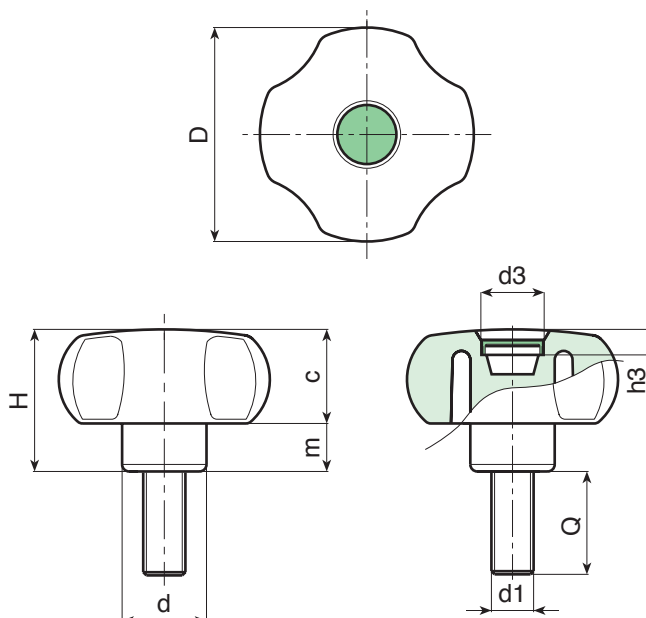

	art.	D	H	d	c	m	d3	h3	LM	d1 6H	Q	g
●	G74740.TM06X..01	40,5	29,5	15,5	18,5	11	20	7,5	100	M06	A.R.	-
●	G74740.TM08X..01	40,5	29,5	15	18,5	11	20	7,5	100	M08	A.R.	-
●	G74740.TM10X..01	40,5	29,5	17,5	18,5	11	20	7,5	100	M10	A.R.	-
●	G74740.TM12X..01	40,5	29,5	21	18,5	11	20	7,5	100	M12	A.R.	-
●	G74750.TM06X..01	49	32	20,5	21,5	11	20	7,5	120	M06	A.R.	-
●	G74750.TM08X..01	49	32	20,5	21,5	11	20	7,5	120	M08	A.R.	-
●	G74750.TM10X..01	49	32	20,5	21,5	11	20	7,5	120	M10	A.R.	-
●	G74750.TM12X..01	49	32	20,5	21,5	11	20	7,5	120	M12	A.R.	-
●	G74760.TM08X..01	59	40	23	25	15	22	7,5	120	M08	A.R.	-
●	G74760.TM10X..01	59	40	23	25	15	22	7,5	120	M10	A.R.	-
●	G74760.TM12X..01	59	40	23	25	15	22	7,5	120	M12	A.R.	-
●	G74760.TM14X..01	59	40	23	25	15	22	7,5	120	M14	A.R.	-

Enter the stud length choice in the two .. of the article code. Lengths by request with 150 pieces minimum quantity.

LM = Maximum mouldable length.

A.R. = by request.

Presumable presence in the stock in %

90% ● 40% ● 5% ●

G791



CYLINDRICAL HANDWHEEL WITH THREADED FEMALE INSERT

Material:
Reinforced polyamide.
Oils and greases resistant.

Surface:
Satin.

Colour:
Black (RAL 9011).

Main Insert:
Brass blind threaded bush (tolerance 6H).



G

SPECIAL REQUEST:

- It is possible to supply the inserts in different materials, on request and for quantities.
- It is possible to supply colours as shown in the table at pag. G-27, on request and for quantities.

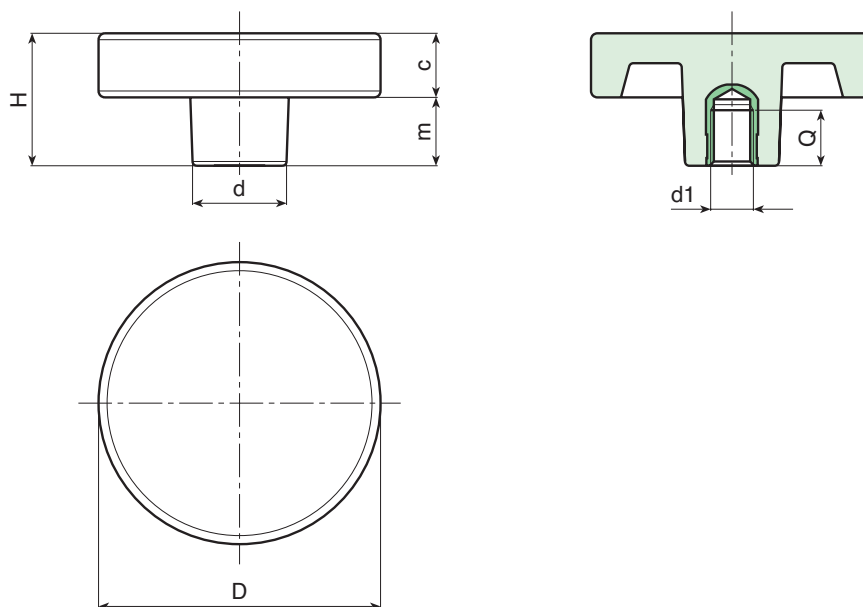

	art.	D	H	d	c	m	d1 6H	Q	g
●	G79136.TM0601	36	17	18	16	1	M06	10	18
●	G79136.TM0801	36	17	18	16	1	M08	15	18
●	G79136.TM1001	36	17	18	16	1	M10	14	19
●	G79150.TM0801	50	30	22	15	15	M08	15	35
●	G79150.TM1001	50	30	22	15	15	M10	14	36
●	G79150.TM1201	50	30	22	15	15	M12	18	40
●	G79166.TM0801	66	30	22	15	15	M08	15	52
●	G79166.TM1001	66	30	22	15	15	M10	14	55
●	G79166.TM1201	66	30	22	15	15	M12	18	58
●	G79166.TM1401	66	30	22	15	15	M14	19	60

G792



CYLINDRICAL HANDWHEEL WITH SMOOTH HOLE INSERT

Material:
Reinforced polyamide.
Oils and greases resistant.

Surface:
Satin.

Colour:
Black (RAL 9011).

Main Insert:
Zinc plated steel insert with smooth through-hole (H10 tolerance).



SPECIAL REQUEST:

- It's possible to supply the inserts with d1 bore by customer design, on request and for quantities.
- It's possible to supply the inserts in different material and treatment-finishes, on request and for quantities.
- It's possible to supply the products with colours as shown in the table at page G-27, on request and for quantities.

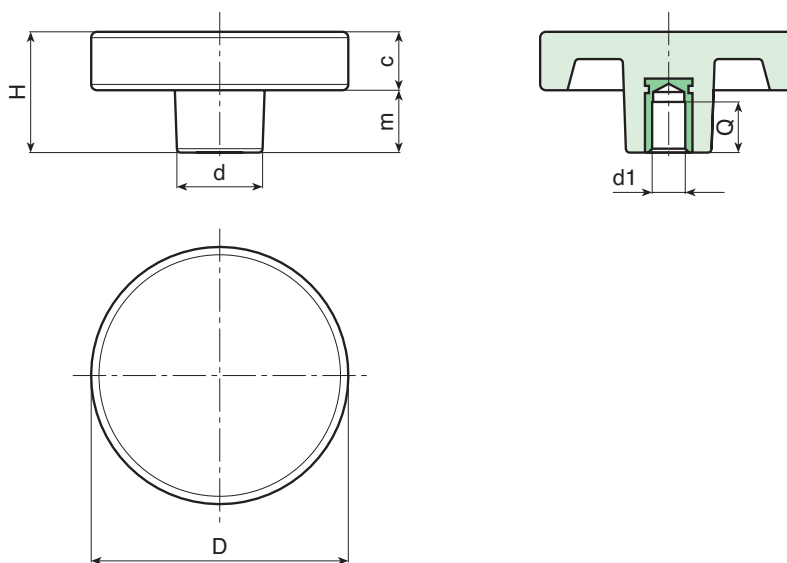

	art.	D	H	d	c	m	Dm	d1 H10	Q	g
●	G79250.TD0601	50	30	22	15	15	12	06	20	62
●	G79266.TD1001	65	30	22	15	15	12	10	20	78

Attention: bore d1 (H10 tolerance) could be produced by request, with 200 pieces minimum.

Dm = It's possible to increase the hole, by boring, until Dm (enlarge).

Presumable presence in the stock in %

90% ● 40% ● 5% ●

G793



PA6
+G.F.

UL94
HB

RoHS
COMPLIANT

CYLINDRICAL HANDWHEEL WITH THREADED STUD

Material:
Reinforced polyamide.
Oils and greases resistant.

Surface:
Satin.

Colour:
Black (RAL 9011).

Main Insert:
Zinc plated steel threaded stud (tolerance 6g).



G

SPECIAL REQUESTS:

- It is possible to supply inserts in different lengths or by special design, on request and for quantities.
- It is possible to supply inserts in different materials, on request and for quantities.
- It is possible to supply colours as shown in the table on page G-27, on request and for quantities.

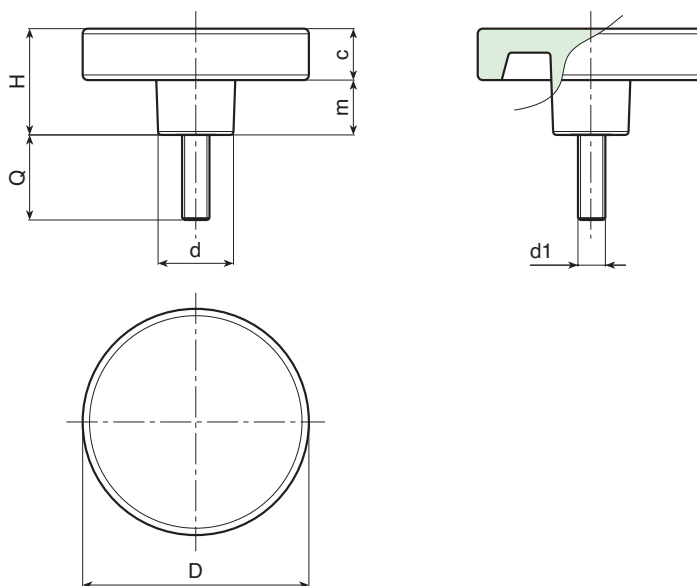

	art.	D	H	d	c	m	LM	d1 6g	Q	g
●	G79336.TM06X3001	36	17	18	16	1	50	M06	30	20
●	G79336.TM08X3001	36	17	18	16	1	50	M08	30	27
●	G79336.TM10X4001	36	17	18	16	1	50	M10	40	42
●	G79350.TM08X2501	50	30	22	15	15	60	M08	25	44
●	G79350.TM10X2501	50	30	22	15	15	60	M10	25	51
●	G79350.TM12X3001	50	30	22	15	15	60	M12	30	80
●	G79366.TM08X1501	65	30	22	15	15	60	M08	15	58
●	G79366.TM10X5001	65	30	22	15	15	60	M10	50	80
●	G79366.TM12X2501	65	30	22	15	15	60	M12	25	97

LM = Maximum mouldable length.

It's possible to have different lengths, by customers requests. Minimum 150 pieces.

G794



KNOB WITH THREADED FEMALE INSERT

Material:
Reinforced polyamide.
Oils and greases resistant.

Surface:
Satin.

Colour:
Black (RAL 9011).

Main Insert:
Brass blind threaded bush (tolerance 6H).

SPECIAL REQUEST:

- It is possible to supply the inserts in different materials, on request and for quantities.
- It is possible to supply colours as shown in the table at pag. G-27, on request and for quantities.

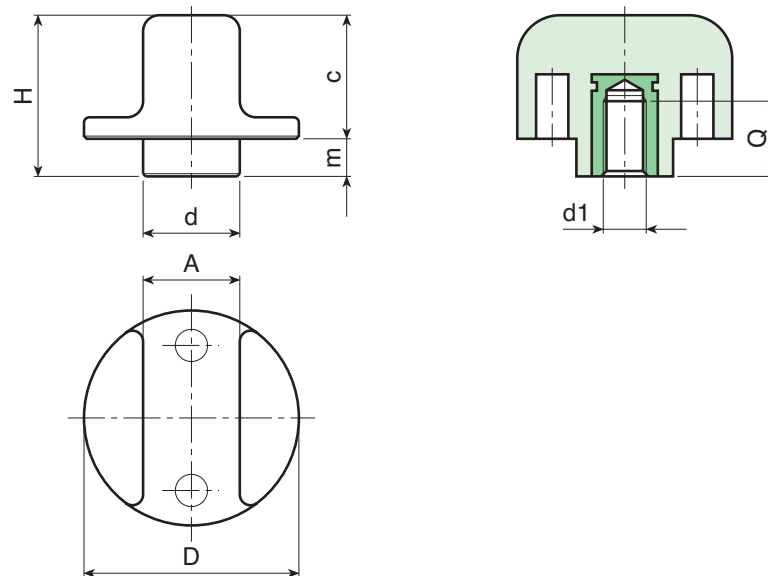

	art.	D	H	d	A	c	m	d1 6H	Q	g
●	G79425.TM0501	25	20	12	10	15	5	M05	11	8
●	G79425.TM0601	25	20	12	10	15	5	M06	9	9
●	G79425.TM0801	25	20	12	10	15	5	M08	8	10
●	G79440.TM0801	40	30	18	18	22	7	M08	15	25
●	G79540.TM1001	40	30	18	18	22	7	M10	14	26
●	G79440.TM1201	40	30	18	18	22	7	M12	14	28

G795



KNOB WITH THREADED STUD

Material:
Reinforced polyamide.
Oils and greases resistant.

Surface:
Satin.

Colour:
Black (RAL 9011).

Main Insert:
Zinc plated steel threaded stud (tolerance 6g).

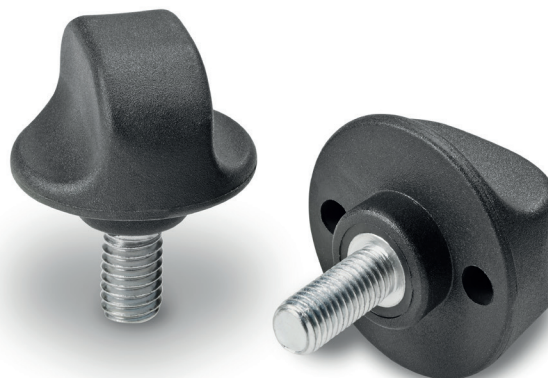

G

SPECIAL REQUESTS:

- It is possible to supply inserts in different lengths or by special design, on request and for quantities.
- It is possible to supply inserts in different materials, on request and for quantities.
- It is possible to supply colours as shown in the table on page G-27, on request and for quantities.

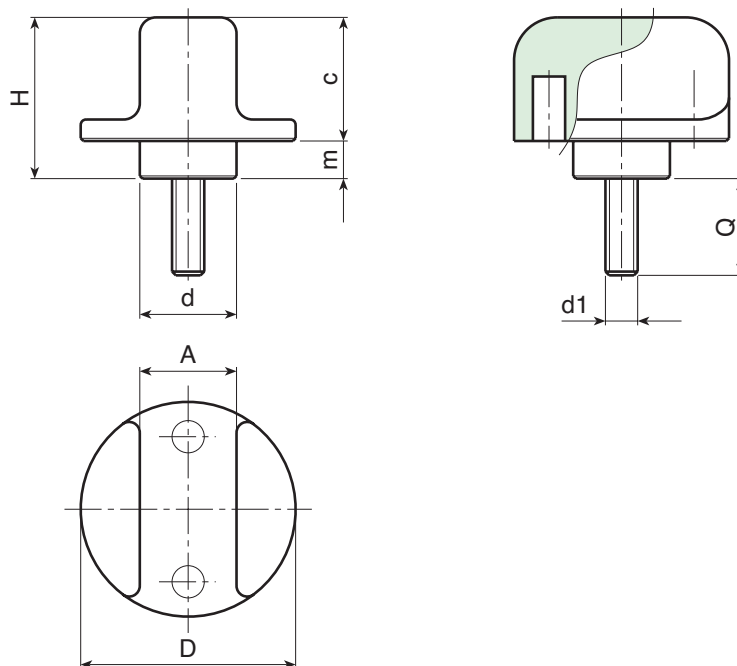

	art.	D	H	d	A	c	m	LM	d1 6g	Q	g
●	G79525.TM05X1601	25	20	12	10	15	5	40	M05	16	12
●	G79525.TM06X3001	25	20	12	10	15	5	40	M06	30	14
●	G79525.TM08X..01	25	20	12	10	15	5	40	M08	A.R.	25
●	G79540.TM08X..01	40	30	18	18	22	7	50	M08	A.R.	40
●	G79540.TM10X3001	40	30	18	18	22	7	50	M10	30	43
●	G79540.TM12X..01	40	30	18	18	22	7	50	M12	A.R.	67

LM = Maximum mouldable length.

It's possible to have different lengths, by customers requests. Minimum 150 pieces.

G796



KNOB WITH THREADED FEMALE INSERT

Material:
Reinforced polyamide.
Oils and greases resistant.

Surface:
Satin.

Colour:
Black (RAL 9011).

Main Insert:
Brass blind threaded bush (tolerance 6H).

SPECIAL REQUEST:

- It is possible to supply the inserts in different materials, on request and for quantities.
- It is possible to supply colours as shown in the table at pag. G-27, on request and for quantities.

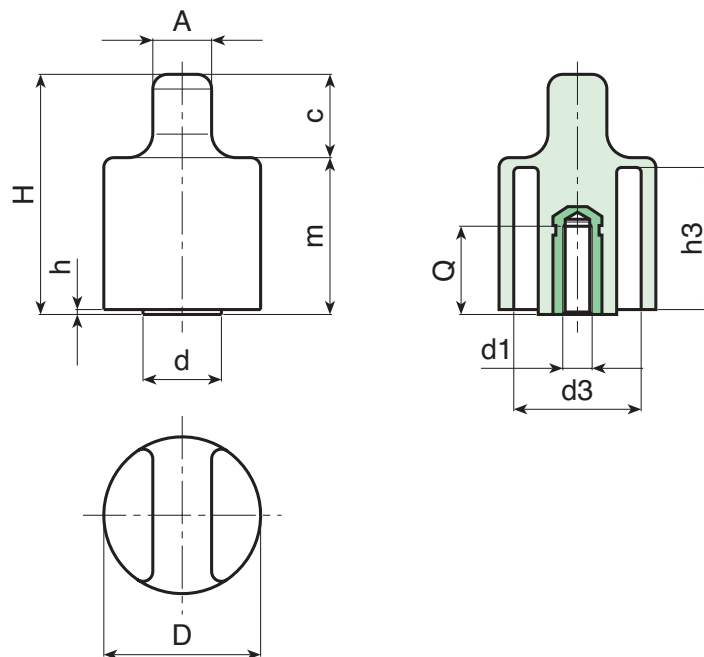

	art.	D	H	d	A	c	m	h	h3	d3	d1 6H	Q	g
●	G79632.TM0601	32	49	16	12	15	34	1	29	25,5	M06	16	33
●	G79632.TM0801	32	49	16	12	15	34	1	29	25,5	M08	14	35
●	G79632.TM1001	32	49	16	12	15	34	1	29	25,5	M10	13	36

G797



KNOB WITH THREADED STUD

Material:

Reinforced polyamide.
Oils and greases resistant.

Surface:

Satin.

Colour:

Black (RAL 9011).

Main Insert:

Zinc plated steel threaded stud (tolerance 6g).

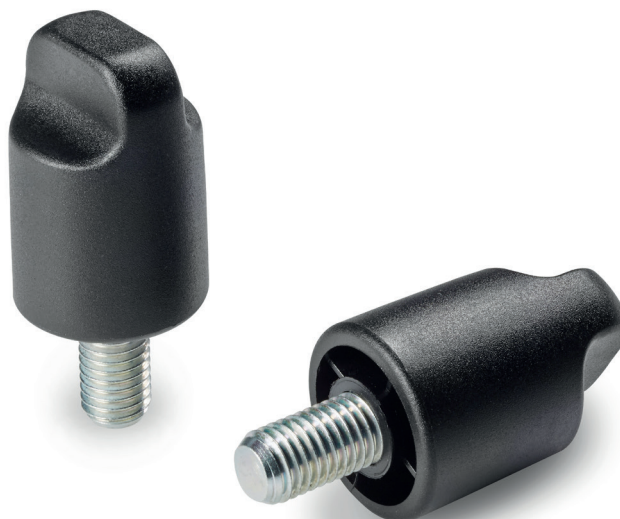

SPECIAL REQUESTS:

- It is possible to supply inserts in different lengths or by special design, on request and for quantities.
- It is possible to supply inserts in different materials, on request and for quantities.
- It is possible to supply colours as shown in the table on page G-27, on request and for quantities.

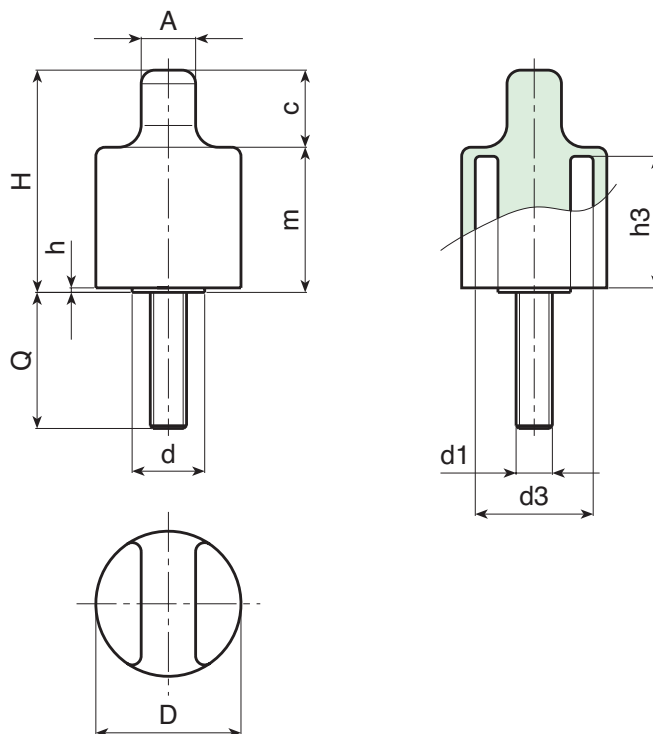

	art.	D	H	d	A	c	m	h	h3	d3	LM	d1 6g	Q	⚖ g
●	G79732.TM06X2001	32	49	16	12	15	34	1	29	25,5	60	M06	20	37
●	G79732.TM08X2501	32	49	16	12	15	34	1	29	25,5	60	M08	25	43
●	G79732.TM10X2001	32	49	16	12	15	34	1	29	25,5	60	M10	40	57
●	G79732.TM12X2001	32	49	16	12	15	34	1	29	25,5	60	M12	20	59

LM = Maximum mouldable length.

It's possible to have different length, by customers requests. Minimum 150 pieces.

G798



ELONGATED KNOB WITH THREADED FEMALE INSERT

Material:
Reinforced polyamide.
Oils and greases resistant.

Surface:
Satin.

Colour:
Black (RAL 9011).

Main Insert:
Brass blind threaded bush (tolerance 6H).

SPECIAL REQUEST:

- It is possible to supply the inserts in different materials, on request and for quantities.
- It is possible to supply colours as shown in the table at pag. G-27, on request and for quantities.

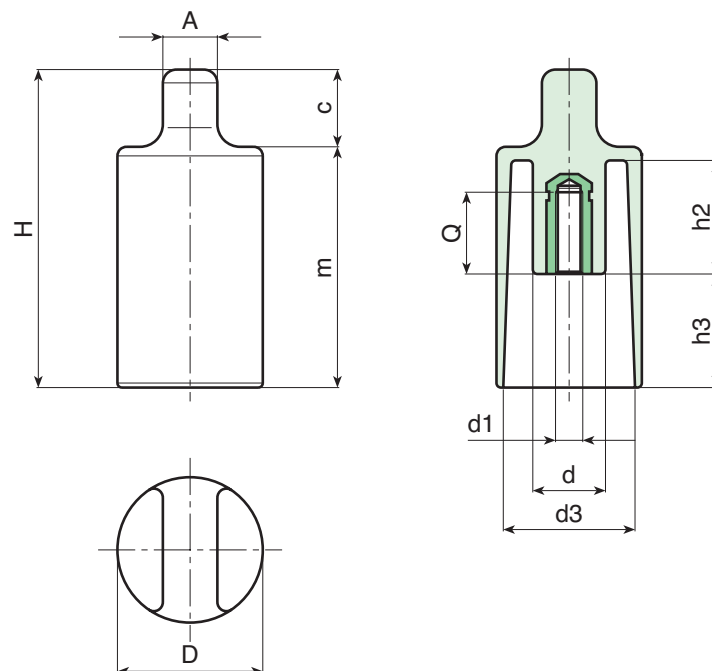

	art.	D	H	d	A	c	m	h2	h3	d3	d1 6H	Q	⚖ g
●	G79832.TM0601	32	69	12	12	15	54	25	26	28	M06	22	32
●	G79832.TM0801	32	69	12	12	15	54	25	26	28	M08	20	38

G799



PA6
+G.F.

UL94
HB

RoHS
COMPLIANT

ELONGATED KNOB WITH THREADED STUD

Material:
Reinforced polyamide.
Oils and greases resistant.

Surface:
Satin.

Colour:
Black (RAL 9011).

Main Insert:
Zinc plated steel threaded stud (tolerance 6g).



G

SPECIAL REQUESTS:



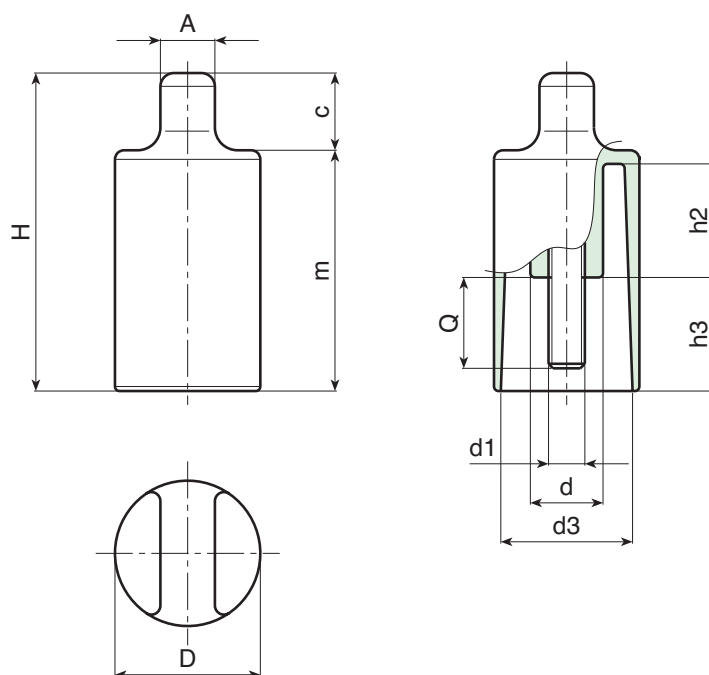











- It is possible to supply inserts in different lengths or by special design, on request and for quantities.
- It is possible to supply inserts in different materials, on request and for quantities.
- It is possible to supply colours as shown in the table on page G-27, on request and for quantities.







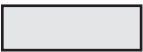









	art.	D	H	d	A	c	m	h2	h3	d3	d1 6g	Q	⚖ g
●	G79932.TM06X1601	32	69	12	12	15	54	25	26	28	M06	16	40
●	G79932.TM08X1601	32	69	12	12	15	54	25	26	28	M08	16	48

COLOUR CHART

RAL COLOURS CODING

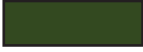
Colour		RAL	Cod.
Black		9011	01
Orange		2004	02
Orange		2011	03
White		9010	04
Blue		5002	05
Blue		5005	06
Blue		5015	07
Blue		5018	19
Blue		5019	21
Blue		5010	22
Yellow		1007	09
Yellow		1021	10
Grey		7024	12
Grey		7035	13
Red		3000	16
Green		6024	17

OTHER COLORS

Colour		Ref.	Cod.
White		-	52
Blue		-	53
Blue		pant. 645 U	54
Blue		pant. 300	55
Grey		-	57
Grey		-	59
Grey		NCS 7500	60
Red		-	64
Red		-	65
Natural		-	66
Green		-	70
Brown		-	71
Cream		-	72
Violet		-	73

AUTHORISED RESELLER

BOTECO Srl

www.boteco.it

36010 ZANE' (VI) - ITALY

Via L. Pettinà 16 (side street of Via Cuso)

Switchboard Tel.:+39-0445-316411 - Fax:+39-0445-316400

Sales Fax:+39-0445-316401 mail: commerciale@boteco.it

Administration Fax:+39-0445-316402 mail: amministr@boteco.it

Technical Fax:+39-0445-316404 mail: tecnico@boteco.it

Certified Mail Box: boteco@pec.botecopec.it

