

ELA-flex SD™ AT 20

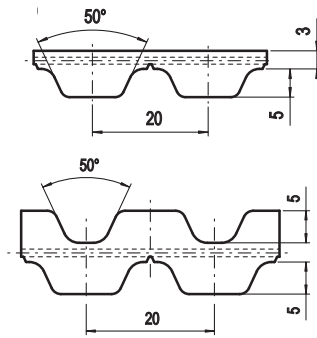
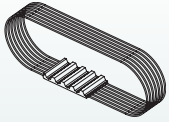

Belt characteristics

- Truly endless polyurethane timing belt with steel tension cords. Metric pitch 20 mm
- Tooth profile and dimension are optimised to guarantee uniform load distribution and minimum deformation under load
- High resistance and low stretch steel cords to guarantee high stability and low elongation
- Reduced polygonal effect with reduced drive vibration and noise
- Transmissible power up to 200 kW
- Rpm up to 6.000 [1/min]
- **Dual tothing available from 1500 mm**
- **HPL cord execution available**

- Maximum width: 150 [mm]
- Width tolerance: ±1,0 [mm]
- Thickness tolerance: ±0,2 [mm]

Technical Data

Belt width [mm]	25	32	50	75	100	150
Allowable tensile load [N]	5810	7920	12140	18480	24290	36960
Weight [kg/m]	0,24	0,31	0,48	0,73	0,97	1,45

Other widths are available on request.

Tooth shear strength

rpm [min ⁻¹]	M _{spez} [Ncm/cm]	P _{spez} [W/cm]	rpm [min ⁻¹]	M _{spez} [Ncm/cm]	P _{spez} [W/cm]	rpm [min ⁻¹]	M _{spez} [Ncm/cm]	P _{spez} [W/cm]
0	48,192	0,000	1200	27,063	34,006	3400	15,842	56,402
20	47,288	0,990	1300	26,251	35,734	3600	15,196	57,284
40	46,438	1,945	1400	25,487	37,363	3800	14,579	58,009
60	45,639	2,867	1440	25,197	37,994	4000	13,993	58,609
80	44,885	3,760	1500	24,771	38,907	4500	12,643	59,576
100	44,175	4,626	1600	24,096	40,370	5000	11,427	59,829
200	41,199	8,628	1700	23,456	41,755	5500	10,320	59,432
300	38,923	12,227	1800	22,845	43,059	6000	9,304	58,456
400	36,911	15,460	1900	22,269	44,305	-	-	-
500	35,157	18,407	2000	21,715	45,477	-	-	-
600	33,617	21,120	2200	20,681	47,641	-	-	-
700	32,248	23,637	2400	19,729	49,580	-	-	-
800	31,016	25,982	2600	18,844	51,303	-	-	-
900	29,899	28,177	2800	18,023	52,841	-	-	-
1000	28,880	30,241	3000	17,252	54,196	-	-	-
1100	27,938	32,180	3200	16,527	55,377	-	-	-

The total power "P" and the total torque "M" transmitted by the belt, are calculated with the following formulas:

$$P \text{ [kW]} = P_{\text{spez}} \cdot Z_e \cdot Z_k \cdot b / 1000$$

$$M \text{ [Nm]} = M_{\text{spez}} \cdot Z_e \cdot Z_k \cdot b / 100$$

$$Z_e = \frac{Z_k}{180} \cdot \arccos \left[\frac{t \cdot (Z_g - Z_k)}{2 \cdot \pi \cdot A} \right]$$

P = power in kW

M = torque in Nm

P_{spez} = specific power

M_{spez} = specific torque

Z_e = number of teeth in mesh of the small pulley

Z_{emax} = 12

Z_k = number of teeth of the small pulley

b = belt width in cm

A = centre distance [mm]

t = pitch

Flexibility

Minimum pulley number of teeth and minimum idler diameter			
Drive without reverse bending		Timing pulley Z _{min}	18
		Flat idler running on belt teeth d _{min}	120 mm
Drive with reverse bending		Timing pulley Z _{min}	25
		Flat idler running on belt back d _{min}	180 mm

Minimum available length

Execution	Max width	
	100 mm	150 mm
Standard	≥ 900 mm	≥ 1500 mm
PAZ	≥ 900 mm	≥ 1800 mm